

kontakti koji idu preko otpora od 1K Connection 1K ohm resistor inseries

GOOD ATMEGA	BAD ATMEGA
2PDO	14PB0
3PD1	15PB1
4PD2	16PB2
5PD3	17PB3
6PD4	18PB4
11PD5	19PB5
12PD6	23PC0
13PD7	24PC1
15PB1	6PD4
16PB2	5PD3
17PB3	4PD2
18PB4	3PD1
19PB5	11PD5
23PC0	LED
25PC2	25PC2
26PC3	9PB6
27PC4	12PD6
28PC5	13PD7

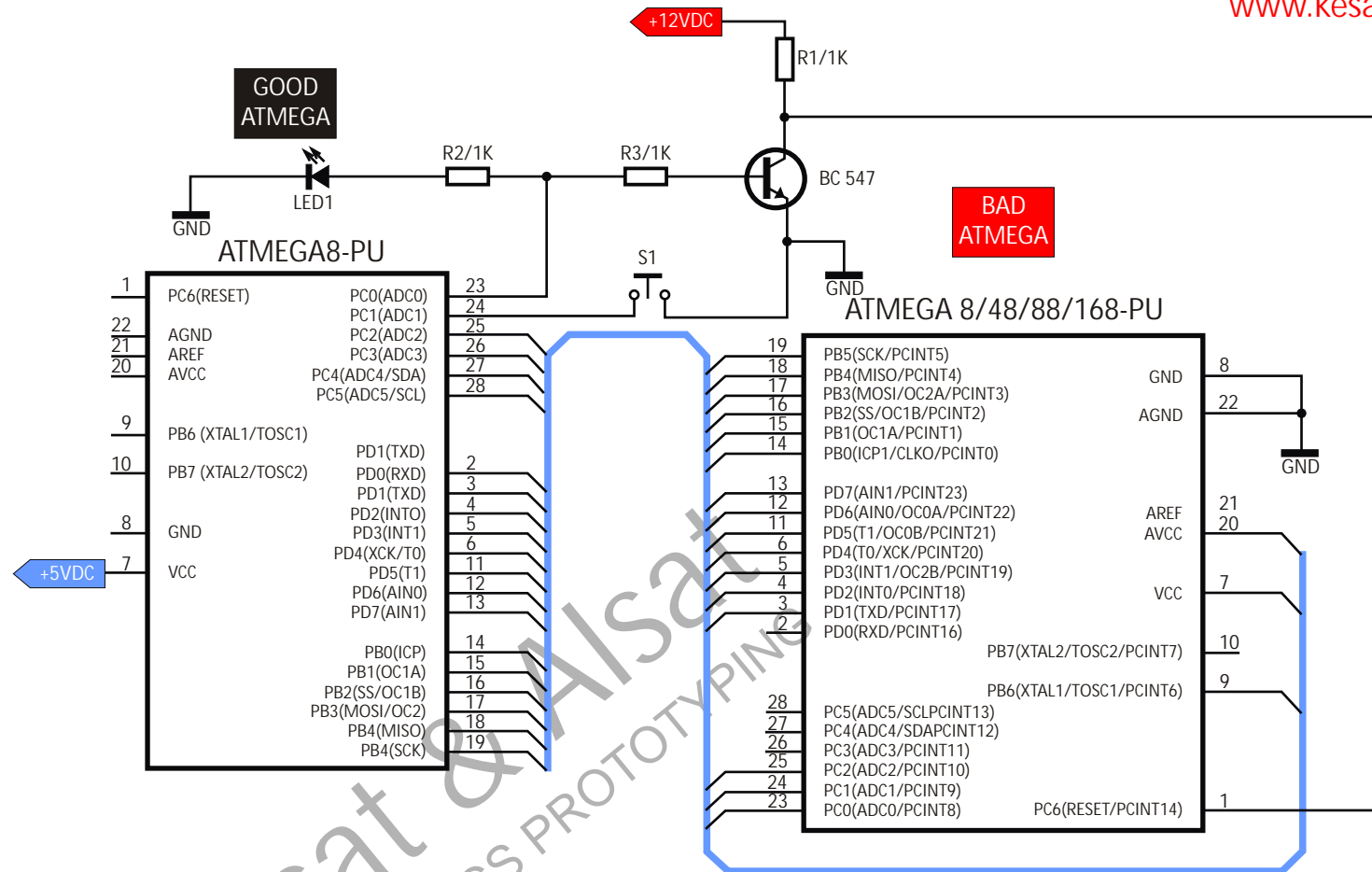

ostali kontakti (bez otpora) other connections (no resistor)

GOOD ATMEGA	BAD ATMEGA
14PB0	20AVCC,7VCC
24PC1	24PC1
GND	GND

Repair dead AVR's - AVR fusebit doctor (HVSP)

 <p>KesatNet</p>	NAME:	AVR "DOCTOR"	
		Elektri na šema	
Electronic Praktikum Group Pljeverlja - Montenegro	DATE: 05.08.2012	DESIGN: Kemal & Alija Dervic	Nr. P24/ 01